



Tube Preamplifier



C2300 Owner's Manual

The lightning flash with arrowhead, within an equilateral triangle, is intended to alert the user to the presence of uninsulated “dangerous voltage” within the product’s enclosure that may be of sufficient magnitude to constitute a risk of electric shock to persons.



AVIS RISQUE DE CHOC ELECTRIQUE - NE PAS OUVRIR.

The exclamation point within an equilateral triangle is intended to alert the user to the presence of important operating and maintenance (servicing) instructions in the literature accompanying the appliance.

WARNING - TO REDUCE RISK OF FIRE OR ELECTRICAL SHOCK, DO NOT EXPOSE THIS EQUIPMENT TO RAIN OR MOISTURE.

NO USER-SERVICEABLE PARTS INSIDE. REFER SERVICING TO QUALIFIED PERSONNEL.

To prevent the risk of electric shock, do not remove cover or back. No user-serviceable parts inside.

IMPORTANT SAFETY INSTRUCTIONS!

PLEASE READ THEM BEFORE OPERATING THIS EQUIPMENT.

1. Read these instructions.
2. Keep these instructions.
3. Heed all warnings.
4. Follow all instructions.
5. Do not use this apparatus near water.
6. Clean only with a dry cloth.
7. Do not block any ventilation openings. Install in accordance with the manufacturer’s instructions.
8. Do not install near any heat sources such as radiators, heat registers, stoves, or other apparatus (including amplifiers) that produce heat.
9. Do not defeat the safety purpose of the polarized or grounding-type plug. A polarized plug has two blades with one wider than the other. A grounding type plug has two blades and a third grounding prong. The wide blade or the third prong are provided for your safety. If the provided plug does not fit into your outlet, consult an electrician for replacement of the obsolete outlet.
10. Protect the power cord from being walked on or pinched particularly at plugs, convenience receptacles, and the point where they exit from the apparatus.
11. Only use attachments/accessories specified by the manufacturer.
12. Use only with the cart, stand, tripod, bracket, or table specified by the manufacturer, or sold with the apparatus. When a cart is used, use caution when moving the cart/apparatus combination to avoid injury from tip-over. 
13. Unplug this apparatus during lightning storms or when unused for long periods of time.
14. Refer all servicing to qualified service personnel. Servicing is required when the apparatus has been damaged in any way, such as power-supply cord or plug is damaged, liquid has been spilled or objects have fallen into the apparatus, the apparatus has been exposed to rain or moisture, does not operate normally, or has been dropped.
15. Do not expose this equipment to dripping or splashing and ensure that no objects filled with liquids, such as vases, are placed on the equipment.
16. To completely disconnect this equipment from the a.c. mains, disconnect the power supply cord plug from the a.c. receptacle.
17. The mains plug of the power supply cord shall remain readily operable.
18. Do not expose batteries to excessive heat such as sunshine, fire or the like.

Thank You

Your decision to own this McIntosh C2300 Tube Preamplifier ranks you at the very top among discriminating music listeners. You now have “The Best.” The McIntosh dedication to “Quality,” is assurance that you will receive many years of musical enjoyment from this unit.

Please take a short time to read the information in this manual. We want you to be as familiar as possible with all the features and functions of your new McIntosh.

Please Take A Moment

The serial number, purchase date and McIntosh Dealer name are important to you for possible insurance claim or future service. The spaces below have been provided for you to record that information:

Serial Number: _____

Purchase Date: _____

Dealer Name: _____

Technical Assistance

If at any time you have questions about your McIntosh product, contact your McIntosh Dealer who is familiar with your McIntosh equipment and any other brands that may be part of your system. If you or your Dealer wish additional help concerning a suspected problem, you can receive technical assistance for all McIntosh products at:

McIntosh Laboratory, Inc.
2 Chambers Street
Binghamton, New York 13903
Phone: 607-723-1545
Fax: 607-724-0549

Customer Service

If it is determined that your McIntosh product is in need of repair, you can return it to your Dealer. You can also return it to the McIntosh Laboratory Service Department. For assistance on factory repair return procedure, contact the McIntosh Service Department at:

McIntosh Laboratory, Inc.
2 Chambers Street
Binghamton, New York 13903
Phone: 607-723-3515
Fax: 607-723-1917

Table of Contents

Safety Instructions	2
Thank You and Please Take a Moment.....	3
Technical Assistance and Customer Service	3
Table of Contents	3
General Information	4
Connector and Cable Information	4
Introduction.....	5
C2300 Features	5
Dimensions	6
Installation	7

Connections:

Rear Panel Connections (Separate Sheet).....	8 and Mc2A
How to Connect the C2300.....	9
Connection Diagrams (Separate Sheets) Mc1A, Mc1B and Mc2B	

Front Panel Features:

Front Panel Displays, Controls, Push-buttons and Jack . 10

Setup:

How to Operate the Setup Mode	11
Default Settings	11
Firmware Version.....	11
Trim Level Adjustment.....	11
Re-Title Inputs.....	12
Meter Illumination	12
Display Brightness.....	13
Power Control Triggers.....	13
Accessory Power Control.....	13
Tube LED.....	13
Passthru.....	13

Remote Control:

Remote Control Push-buttons.....	14
How to Operate by Remote Control	15

Operation:

How to Operate the C2300	16
--------------------------------	----

Additional Information:

Technical Description	20
Specifications.....	22
Packing Instruction.....	23

General Information

1. The C2300 uses Vacuum Tubes for amplifying the audio signal. The C2300 is designed to have only qualified Service Personnel perform any part(s) replacement including all the vacuum tubes.
2. For additional connection information, refer to the owner's manual(s) for any component(s) connected to the C2300 Tube Preamplifier.
3. The Main AC Power going to the C2300 and any other McIntosh Component(s) should not be applied until all the system components are connected together. Failure to do so could result in malfunctioning of some or all of the system's normal operations. When the C2300 and other McIntosh Components are in their Standby Power Off Mode, the Microprocessor's Circuitry inside each component is active and communication is occurring between them.
4. Up to two Sensors can be wired in parallel for Remote Control of the C2300 from other rooms.
5. Balanced and Unbalanced Inputs and Outputs can be mixed. For example, you may connect signal sources to Unbalanced Inputs and send signals from the Balanced Outputs. You can also use Balanced and Unbalanced Outputs simultaneously, connected to different Power Amplifiers.

Connector and Cable Information

XLR Connectors

Below is the Pin configuration for the XLR Balanced Input and Output Connectors on the C2300. Refer to the diagrams for connections:

- PIN 1: Shield/Ground
- PIN 2: + Output
- PIN 3: - Output

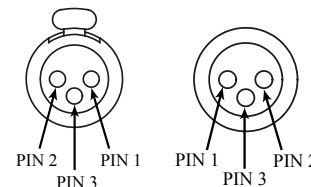

Power Control and Trigger Connectors

The C2300 Power Control and Trigger Output Jacks send Power On/Off Signals when connected to McIntosh and other Components. An additional connection on the Main Power Control Jack is for controlling the illumination of the Power Output Meters on McIntosh Power Amplifiers. A 1/8 inch stereo mini phone plug is used for connection to the Power Control and Trigger Outputs on the C2300.

Main Output Jack

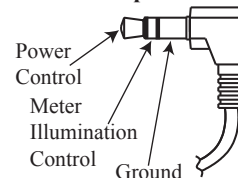

Output 1 and 2, ACC Jacks

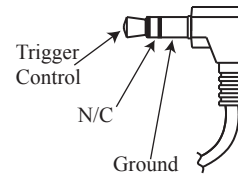
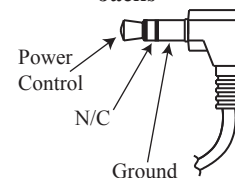

Note: The Data, Power Control and Trigger Connecting Cable is available from the McIntosh Parts Department:

Data, Power Control and Trigger Cable Part No. 170-202
Six foot, shielded 2 conductor, with 1/8 inch stereo mini phone plugs on each end.

Data Port Connectors

The C2300 Data Out Ports send Remote Control Signals to McIntosh Source Components. A 1/8 inch stereo mini phone plug is used for connection.

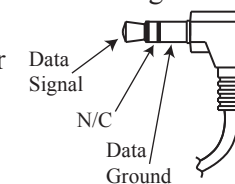

Introduction

The McIntosh C2300 Tube Preamplifier is one of the finest Tube Preamplifiers ever created. The versatile Preamplifier provides connections for various input sources and outputs to drive multiple Power Amplifiers. The C2300 reproduction is sonically transparent and absolutely accurate. The McIntosh Sound is “The Sound of the Music Itself.”

C2300 Features

• Electromagnetic Input Switching with Level Trim Adjustment

Digital Logic integrated circuits drive Electromagnetic Switches on all Inputs and operating functions for reliable, noiseless, distortion free switching. All eight Inputs on the C2300 can be matched in level, so there are no abrupt changes in volume levels between the different Inputs. There is also a Record Monitor function for checking the progress of a recording.

• Moving Coil and Moving Magnet Phono Inputs

The C2300 contains two different precision Phono Preamplifier Circuits. One for low output Moving Coil Phono Cartridges with selectable resistance loading, the other is for Moving Magnet Cartridges with selectable capacitive loading. Both circuits use the latest designs to provide the lowest possible noise and distortion. The RIAA Correction Equalization Circuitry utilizes close tolerance resistors and capacitors for an extremely flat frequency response.

• Balanced Inputs

The Balanced Inputs allow the connection of a source component using long cable lengths without a loss in sound quality.

• Precision Tracking Volume Control

Volume levels are controlled by a new Multi-Stage Precision Digitally Controlled Attenuator System with a tracking accuracy of 0.1dB.

• Variable Rate Volume and Balance Control Selection

The C2300 Tube Preamplifier’s Volume and Balance Control Circuitry provides an ideal rate of change with control rotation.

• Assignable Tone Controls with Bypass

The C2300 remembers the Bass and Treble Control Settings or the Tone Circuitry Bypass Option for each input.

• Alphanumeric Fluorescent Display

The Multifunction Front Panel Display indicates the Source Selection, Volume and Balance Levels. Setup Mode

Selections and Adjustments are also displayed. The display intensity is adjustable.

• Precision Parts

Only the finest precision 1% tolerance resistors are used throughout.

• Low Distortion

Distortion levels of all types are less than 0.08%. Music is amplified with total transparency and accuracy.

• Passthru Mode

The Automatic Passthru Mode allows the C2300 to become part of a Multichannel Sound System for DVD-Audio, SACD and Home Theater Movies.

• Output Switching

Front panel Output Push-buttons control two Switched Outputs that allow sending signals to two separate Power Amplifiers.

• Remote Control with External Sensor Input

The Remote Control provides control of the C2300 operating functions and any McIntosh Source Components connected to it. Enjoy your McIntosh System from other rooms in your home by connecting external sensors.

• Power Control Output and Trigger Assignment

A Power Control connection for convenient Turn-On of McIntosh Power Amplifiers, Source Components and Accessories is included. Two of the Power Control Outputs may be assigned to activate when a given Input is selected.

• Special Power Supply

Fully regulated Power Supplies and a special R-Core Power Transformer ensure stable noise free operation even though the power line varies.

• Extruded Side Panels

The sides of the VP1000 are extruded aluminum panels with a bead blast textured surface and a black anodized finish.

• Fiber Optic Solid State Front Panel Illumination

The even Illumination of the Front Panel is accomplished by the combination of custom designed Fiber Optic Light Diffusers and extra long life Light Emitting Diodes (LEDs). The glass Front Panel ensures the pristine beauty of the C2300 will be retained for many years.



Dimensions

The following dimensions can assist in determining the best location for your C2300. There is additional information on the next page pertaining to installing the C2300 into cabinets.

Front View of the C2300

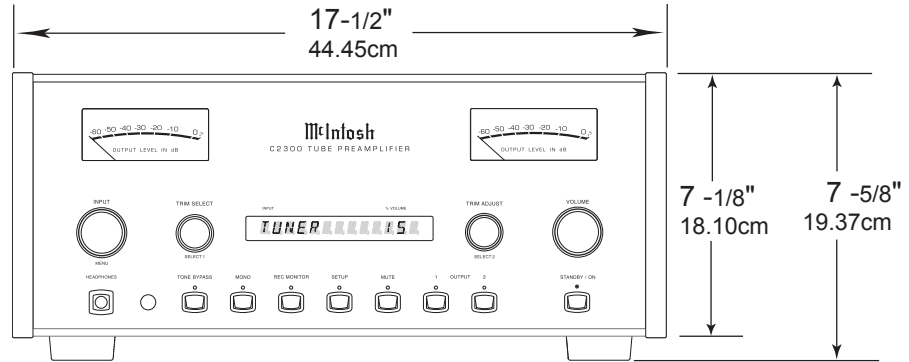

Rear View of the C2300

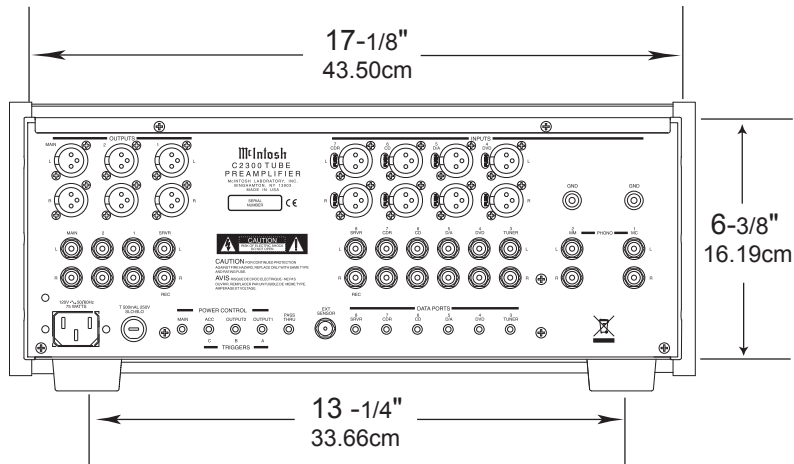

Side View of the C2300

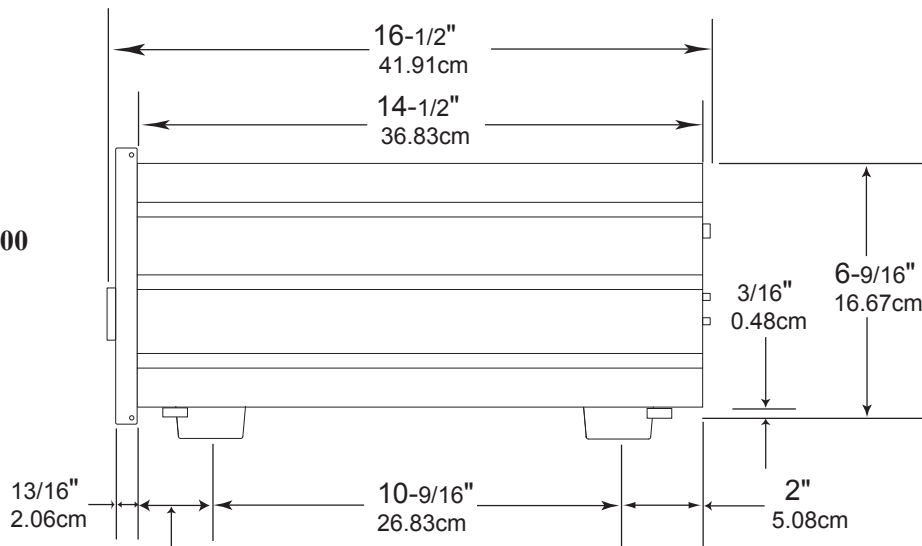

Installation

The C2300 can be placed upright on a table or shelf, standing on its four feet. It also can be custom installed in a piece of furniture or cabinet of your choice. The four feet may be removed from the bottom of the C2300 when it is custom installed as outlined below. The four feet together with the mounting screws should be retained for possible future use if the C2300 is removed from the custom installation and used free standing. The required panel cutout, ventilation cutout and unit dimensions are shown.

Always provide adequate ventilation for your C2300.

Cool operation ensures the longest possible operating life for any electronic instrument. Do not install the C2300 directly above a heat generating component such as a high powered amplifier. If all the components are installed in a single cabinet, a quiet running ventilation fan can be a definite asset in maintaining all the system components at the coolest possible operating temperature.

A custom cabinet installation should provide the following minimum spacing dimensions for cool operation.

Allow at least 6 inches (15.24cm) above the top, 2 inches (5.08cm) below the bottom and 1 inch (2.54cm)

on each side of the Tube Preamplifier, so that airflow is not obstructed. Allow 19-1/2 inches (49.53cm) depth behind the front panel. Allow 1-1/8 inch (2.9cm) in front of the mounting panel for knob clearance. Be sure to cut out a ventilation hole in the mounting shelf according to the dimensions in the drawing.

C2300 Front Panel Custom Cabinet Cutout

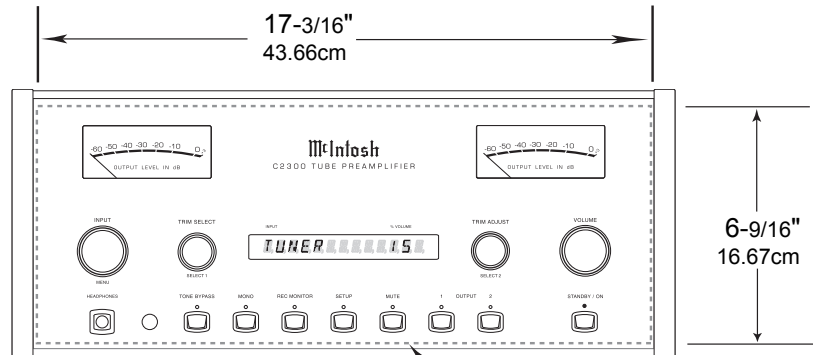

C2300 Side View in Custom Cabinet

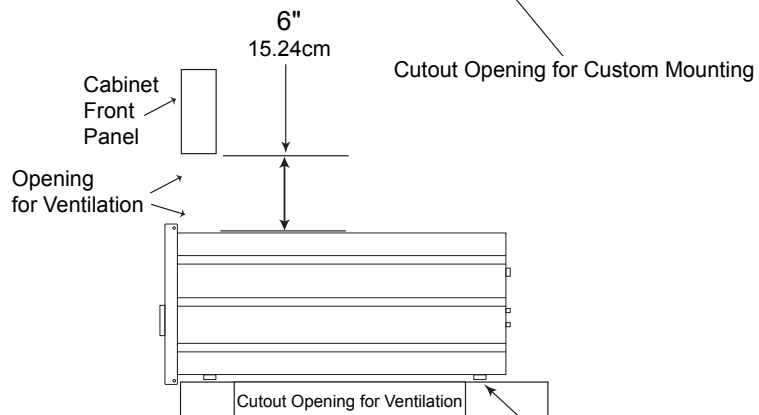

C2300 Bottom View in Custom Cabinet

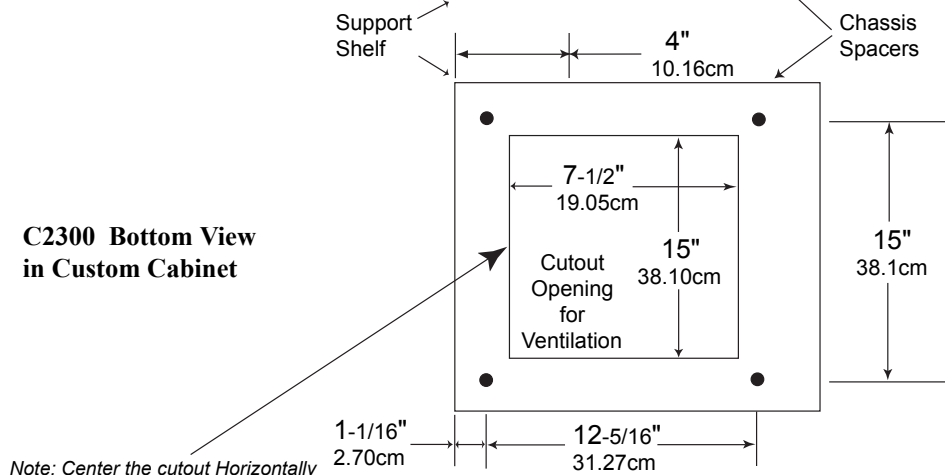

Note: Center the cutout horizontally on the unit. For purposes of clarity, the above illustration is not drawn to scale.



Rear Panel Connections

The identification of Rear Panel Connections for the C2300 Tube Preamplifier is located on a separate folded sheet contained in the Owner's Manual Packet. Refer to separate sheet "Mc2A" for the Rear Panel Connections.

C2300 Tube Preamplifier Rear Panel

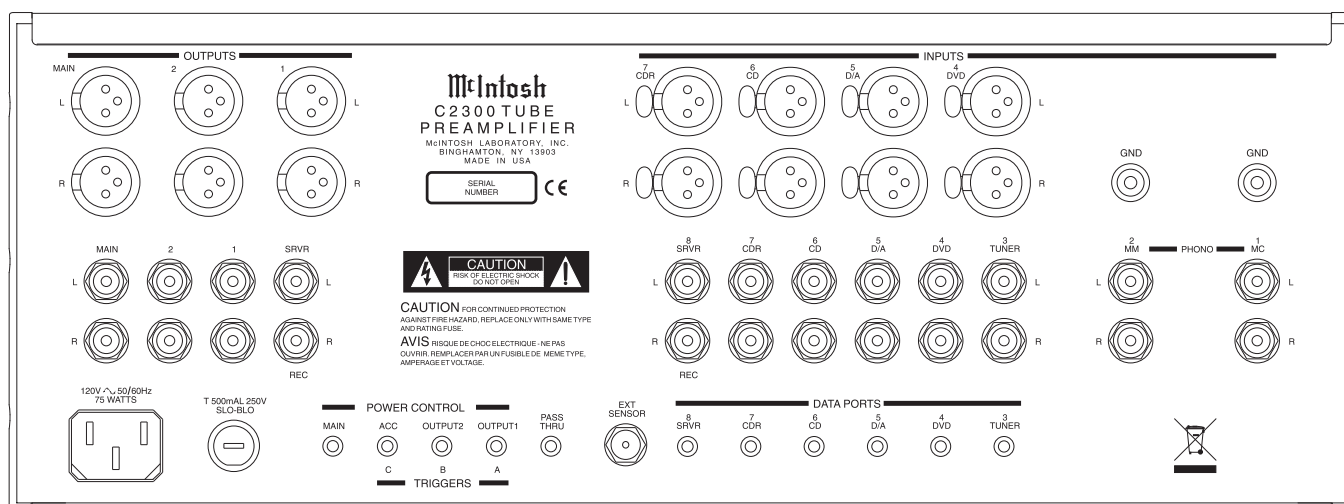

How to Connect the C2300

The C2300 has the ability to automatically switch power On/Off to McIntosh Source Components via the Power Control connections. The Data Port Connections allow for the remote operation of basic functions using the C2300 Remote Control. With an external sensor connected to the C2300, remote control operation of the system is possible from another room and/or when the C2300 is located in a cabinet with the doors closed.

The connection instructions below, together with the C2300 Input and Output Connection Diagrams located on the separate folded sheets “Mc1A/1B and Mc2A/2B”, is an example of a typical audio system. Your system may vary from this, however the actual components would be connected in a similar manner. For additional information refer to “Connector and Cable Information” on page 4.

Power Control Connections:

1. Connect a Control Cable from the C2300 POWER CONTROL ACC(C) Jack to the Power Control In on the McIntosh SACD/CD Player.
2. Connect a Control Cable from the McIntosh SACD/CD Player Power Control Out jack to the McIntosh D/A Converter Power Control In Jack.
3. Connect a Control Cable from the McIntosh D/A Converter Power Control Out jack to the McIntosh Tuner Power Control In Jack.
4. Connect a Control Cable from the McIntosh Tuner Power Control Out jack to the McIntosh Music Server Power Control In Jack.
5. Connect a Control Cable from the C2300 POWER CONTROL MAIN Out jack to the McIntosh Power Amplifier Left Channel Power Control In Jack. Connect a Control Cable from the Left Channel Power Amplifier Power Control Out to the Right Channel Power Amplifier Power Control In Jack.
6. Optionally connect a Control Cable from the C2300 POWER CONTROL OUTPUT 1 jack to the McIntosh Power Amplifier (Secondary Room) Power Control In Jack.
7. Connect any additional McIntosh Components in a similar manner, as outlined in steps 1 thru 4.

Data Control Connections:

8. Connect a Control Cable from the C2300 TUNER DATA PORTS Jack to the McIntosh TUNER1 Data In Jack.
9. Connect a Control Cable from the C2300 CD DATA PORT Jack to the McIntosh SACD/CD Player Data In jack.
10. Connect a Control Cable from the C2300 SRVR DATA PORT Jack to the McIntosh Music Server Data In jack.
11. Connect a Control Cable from the C2300 D/A DATA

PORT Jack to the McIntosh D/A Converter Data In jack.

12. Connect any additional McIntosh Components in a similar manner, as outlined in steps 8 thru 11.

Sensor Connections:

13. Connect a RG59U or RG6U Cable from the C2300 EXT SENSOR “F” Connector to the McIntosh Sensor “F” Connector.

Audio Connections:

14. Connect an Audio Cable from the C2300 TUNER INPUT Jacks to the McIntosh TUNER1 Fixed Output Jacks.
15. Connect Balanced Cables from the C2300 CD INPUT Jacks to the McIntosh SACD/CD Player Fixed Balanced Output Jacks.
16. Connect an Audio Cable from the C2300 SRVR INPUT Jacks to the McIntosh Music Server Output Jacks.
17. Connect an Audio Cable from the C2300 SRVR OUTPUT Jacks to the McIntosh Music Server Input 1 Jacks.
18. Connect an Balanced Cables from the C2300 D/A OUTPUT Jacks to the McIntosh D/A Converter output Jacks.
19. Connect the Audio Cables coming from the Turntable to the C2300 MC PHONO INPUT Jacks.

Note: Unbalanced Audio Cables may be used instead of the Balanced Cables, but not both.

Note: If the Turntable has a Moving Magnet Cartridge connect the audio cables to the C2300 MM PHONO INPUT instead of the MC Input.

20. Connect Balanced Cables from the C2300 MAIN OUTPUT jacks to the McIntosh Power Amplifiers (Main Left and Right) Input jacks.
21. Connect an Audio Cable from the C2300 OUTPUT 1 jacks to the McIntosh Power Amplifier (Secondary) Input jacks.
22. Connect any additional McIntosh Components in a similar manner, as outlined in steps 14 thru 21.

Optional “PassThru” Connections:

23. Connect Audio Cables or Balanced Cables from the McIntosh MX Series A/V Control Center Front Left and Right Channel Outputs to the CDR Input Jacks.
24. Connect a Control Cable from the C2300 PASSTHRU to McIntosh MX Series A/V Control Center Zone A Power Control Output.

Ground Connections:

25. Connect the Gound Cable coming from the Turntable to the C2300 GND Binding Post.

AC Power Cords Connections:

26. Connect the C2300 and any remaining components’ AC Power Cords to a live AC outlet as illustrated.



Front Panel Displays, Controls, Push-buttons and Jack

INPUT Control selects the desired audio signals for listening and recording. It is also used in the setup mode for various functions

IR Sensor receives commands from a Remote Control

DISPLAY indicates the Sources, Volume, other Audio Settings, Operational Functions and Setup Mode Settings

METER indicates the Preamplifier's Right Channel relative Output Level

METER indicates the Preamplifier's Left Channel relative Output Level

TRIM SELECT allows selection of various types of audio settings. It is also used in the setup mode for various functions

TRIM ADJUST allows adjustment of various types audio settings. It is also used in the setup mode for various functions

VOLUME Control adjusts the listening level for both channels

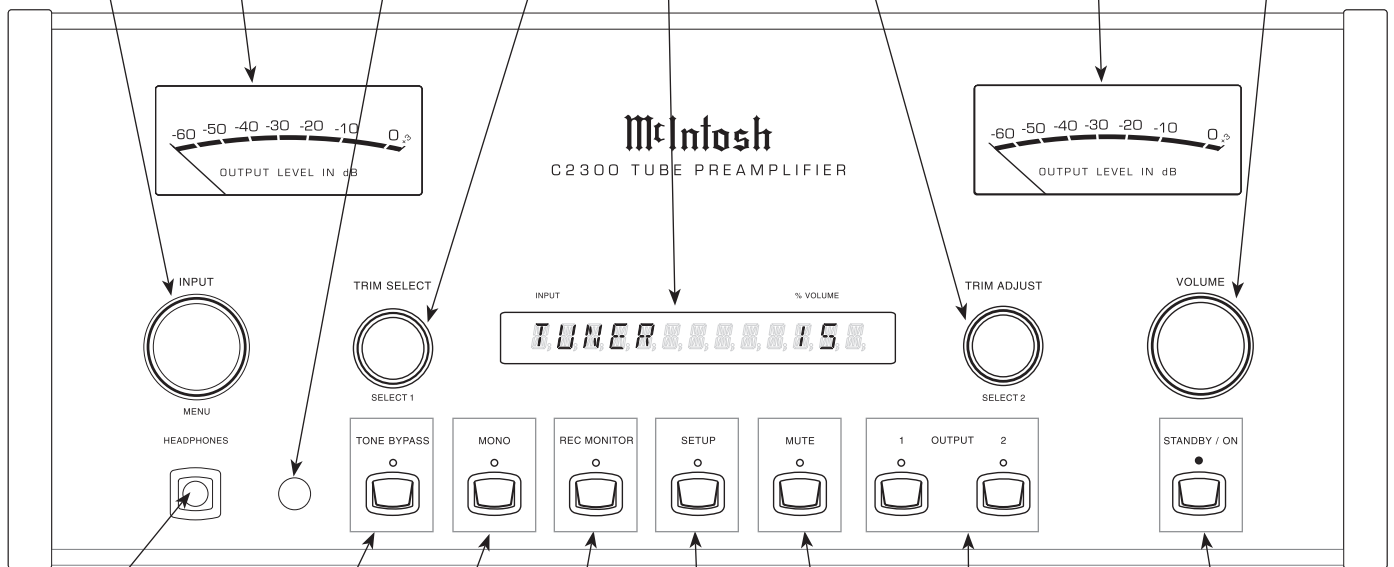

Connection for low impedance dynamic headphones with 1/4" (0.64cm) stereo phone type plug, for private listening

MONO with indicator, combines the Left and Right Channel signals for Monophonic Sound

SETUP Mode Push-button with indicator, allows the changing of the default settings for Inputs, Levels, Special Functions and the Display

OUTPUTS 1 and 2 Push-buttons with indicators, allow the C2300 to switch Power Control and Audio to two separate Stereo Power Amplifiers

TONE BYPASS with indicator, when activated the audio signal bypasses the Tone Controls

REC MONITOR Push-button with indicator, allows listening to the playback of REC/SRVR Source while the recording is in process

MUTE Push-button with indicator, activates different Muting Modes

STANDBY/ON Push-button switches the C2300 ON or OFF (Standby) and resets the microprocessors

How to Operate the Setup Modes

Your McIntosh C2300 has been factory configured for default operating settings that will allow immediate enjoyment of superb audio without the need for further adjustments. If you wish to make changes to the factory default settings, a Setup Feature is provided to customize the operating settings using the Front Panel Alphanumeric Display. Refer to the C2300 Front Panel Illustration on the previous page while performing the following steps.

Note: If the C2300 is currently, On proceed to step 2.

1. Press the STANDBY/ON Push-button to switch On the C2300. The title TUBE WARMUP will appear on the Front Panel Alphanumeric Display. Refer to figure 1.



Figure 1

Note: The Red LED above the STANDBY/ON Push-button lights to indicate the C2300 is connected to AC Power.

2. Press the C2300 Front Panel SETUP Push-button. The LED above the SETUP Push-button will illuminate and the Front Panel Display will indicate C2300 V1.00 or higher. Refer to figure 2.



Figure 2

Note: The Front Panel Display will indicate C2300 V1.00 or higher the first time, after that it will display whatever Setup Mode was last accessed.

3. Rotate the MENU (INPUT) Control and notice the Setup Mode goes forwards through eight different possible adjustment selections and one informational display.
4. To exit from a specific Setup Mode, press the SETUP Push-button a second time. The LED above the SETUP Push-button will extinguish and the Front Panel Display will revert back to its normal display. Refer to figure 3.



Figure 3

Default Settings

The Default Settings Chart below indicates the Function Name, default Setting and the page number for additional information.

Default Settings		
Function Name	Setting	Page No.
C2300	V _ _ _	11
TRIM	TUNER 0.0	11
INPUT	3 * TUN	12
METER	ON	12
DISPLAY	7	13
TRIGGER	TUNER> - -	13
ACCESSORY <C>	MAIN	13
TUBE LED	ON	13
PASSTHRU	OFF	13

Firmware Version

The C2300 functionality is controlled by internal software that is known as Firmware. The Version of the Firmware in the C2300 can be identified at any time by utilizing the Setup Mode.

1. Press the SETUP Push-button to access the Setup Mode.
2. Rotate the MENU (INPUT) Control until C2300 V1.00 or higher appears. Refer to figure 2.
3. The number after the character “V” is the Firmware number.
4. Press the SETUP Push-button to exit the Setup Mode.

Trim Level Adjustment

Source Components can have slightly different volume levels resulting in the need to readjust the C2300 Volume Control when switching between different sources. The C2300 allows the adjustment of levels for each of the Source Inputs for the same relative volume. The Tuner and CD Inputs are used in the following example.

Note: The range of adjustment is ± 6 dB. The Tape/Record Output Levels are unaffected by any changes in the Level Trim Settings. The Trim adjustments made are retained in permanent memory. They can be changed by performing a new Trim Procedure. The Tuner Input Volume Level can serve as a reference or choose another source frequently listened to. The reference Input Source should be set to a Trim Level of 00.

1. Rotate the INPUT Control to select the Tuner Input and adjust the VOLUME Control to the desired listening level.



2. Press the SETUP Push-button to access the Setup Mode.
3. Rotate the MENU (INPUT) Control until “TRIM TUN 0.0” appears on the Front Panel Alphanumeric Display. Refer to figure 4.



Figure 4

Note: If necessary, rotate the SELECT 1 (TRIM SELECT) Control for “TUN” and rotate the SELECT 2 (TRIM ADJUST) for ”0.0”.

4. Rotate the SELECT 1 Control or use the Remote Control ◀INPUT▶ push-button until the display indicates “TRIM CD 0.0”.
5. Rotate the SELECT 2 Control or use the Remote Control LEVEL ▼ or ▲ Push-buttons until Listening Volume Level of the CD Input is the same as the Tuner Volume Level. The figure 5 illustration indicates a -2.5dB decrease in the CD Level.



Figure 5

6. Rotate the SELECT 1 Control until the name of the next Input to be adjusted is displayed.
7. Repeat steps 5 and 6 until all the Inputs with sources connected to the C2300 have the same relative volume levels when switching between them. Record any changes made to the various inputs from the default settings in the “Input Source Settings” chart below.
8. Press the SETUP Push-button to exit the Setup Mode.

Input Source Settings			
Default Title	New Title	Trim	Trigger
TUNER			
DVD			
D/A			
CD			
CDR			
SERVER			
MC PHONO			
MM PHONO			

Re-Title Inputs

The C2300 provides the ability to change the default Input Titles to match the components in your system. In the following example the CDR Input will be renamed and appear as AUX on the Front Panel Alphanumeric Display.

Notes: 1. One of the high level Inputs may be renamed to AUX or switched Off. If any input is switched Off its name will no longer appear on the Front Panel Alphanumeric Display when using the INPUT Control, nor is it accessible with the Remote Control.

2. When a high level input is switched Off its name will become available to the remaining high level inputs.
3. The Phono MC and Phono MM Inputs are designed for connection of a turntable only and thus the title is not changeable. However, the Phono Input may be switched Off.

1. Press the SETUP Push-button to access the Setup Mode.
2. Rotate the MENU Control until “INPUT 3 *TUN” appears on the Front Panel Alphanumeric Display.
3. Rotate the SELECT 1 Control until “INPUT 7 *CDR” appears on the Front Panel Alphanumeric Display. Refer to figure 6.



Figure 6

3. Rotate the SELECT 2 Control until the Front Panel Alphanumeric Display indicates “INPUT 7 AUX”. Refer to figure 7.



Figure 7

4. Press the SETUP Push-button to exit the Setup Mode.

Meter Illumination On/Off

The Front Panel Meter Illumination may be switched On or Off. Follow the steps below to switch the Meter Illumination Off.

1. Press the SETUP Push-button to access the Setup Mode.
2. Rotate the MENU Control until the words METER ON appears.
3. Rotate the SELECT 2 Control until the Front Panel Alphanumeric Display indicates “METER OFF”.
4. Press the SETUP Push-button to exit the Setup Mode.

Display Brightness

The Front Panel Alphanumeric DISPLAY Brightness may be varied from a setting of 1 (Dim) to 7 (Bright). Follow the steps below for reducing the Display Brightness.

1. Press the SETUP Push-button to access the Setup Mode.
2. Rotate the MENU Control until the word DISPLAY 7 appears.
3. Rotate the SELECT 2 Control until the Front Panel Alphanumeric Display indicates "Display 3".
4. Press the SETUP Push-button to exit the Setup Mode.

Power Control Triggers

The OUTPUT 1(A) and OUTPUT 2(B) Power Control Outputs are reassignable to activate only when a given Input is selected. In the following example, the Power Control OUTPUT 1(A) Jack will be set to function as TRIGGER A for the DVD Input.

1. Press the SETUP Push-button to access the Setup Mode.
2. Rotate the MENU Control until "TRIG TUNER > - -" appears on the Front Panel Alphanumeric Display. Refer to figure 8.



Figure 8

3. Rotate the SELECT 1 Control until the display indicates "TRIG DVD > - -".
4. Rotate the SELECT 2 Control until the display indicates "TRIG DVD > A ". Refer to figure 9.



Figure 9

5. Press the SETUP Push-button to exit the Setup Mode.

Accessory Power Control

The ACC (C) Power Control Output is reassignable from the default setting of going ON/OFF with the C2300 (Main), to being controlled by the Remote Control ACC ON/OFF Push-buttons. To reassign it perform the following:

1. Press the SETUP Push-button to access the Setup Mode.
2. Rotate the MENU Control until "ACC < C > MAIN" appears on the Front Panel Alphanumeric Display.
3. Rotate the SELECT 2 Control until the display indi-



Figure 10

icates "ACC < C > ON". Refer to figure 10.

Tube LED

To switch Off the Tube LED green illumination perform the following:

1. Press the SETUP Push-button to access the Setup Mode.
2. Rotate the MENU Control until "TUBE LED ON" appears on the Front Panel Alphanumeric Display.
3. Rotate the SELECT 2 Control until the display indicates "TUBE LED OFF".
4. Press the SETUP Push-button to exit the Setup Mode.

Passthru

The C2300 can be part of a Multichannel Sound System for SACD, DVD-Audio and Home Theater. The Right and Left Front Channels from a McIntosh A/V Control Center or Surround Decoder can "Passthru" the C2300 and onto its associated Power Amplifier(s). The Setup Mode allows the activation of the Passthru Mode and the Selection of the C2300 Input (Input numbers 3 - 8 on the Rear Panel) that will be used for the Right and Left Front Channels. In the example below, the Right and Left Front Channels from the Multichannel Processor/Decoder will be connected to the CDR (7) Input Jacks on the C2300. Refer to page 9 for additional connection information.

1. Press the SETUP Push-button to access the Setup Mode.
2. Rotate the MENU Control until "PASSTHRU OFF" appears on the Front Panel Alphanumeric Display.
3. Rotate the SELECT 2 Control until the display indicates "PASSTHRU 7 ". Refer to figure 11.



Figure 11

4. Press the SETUP Push-button to exit the Setup Mode.

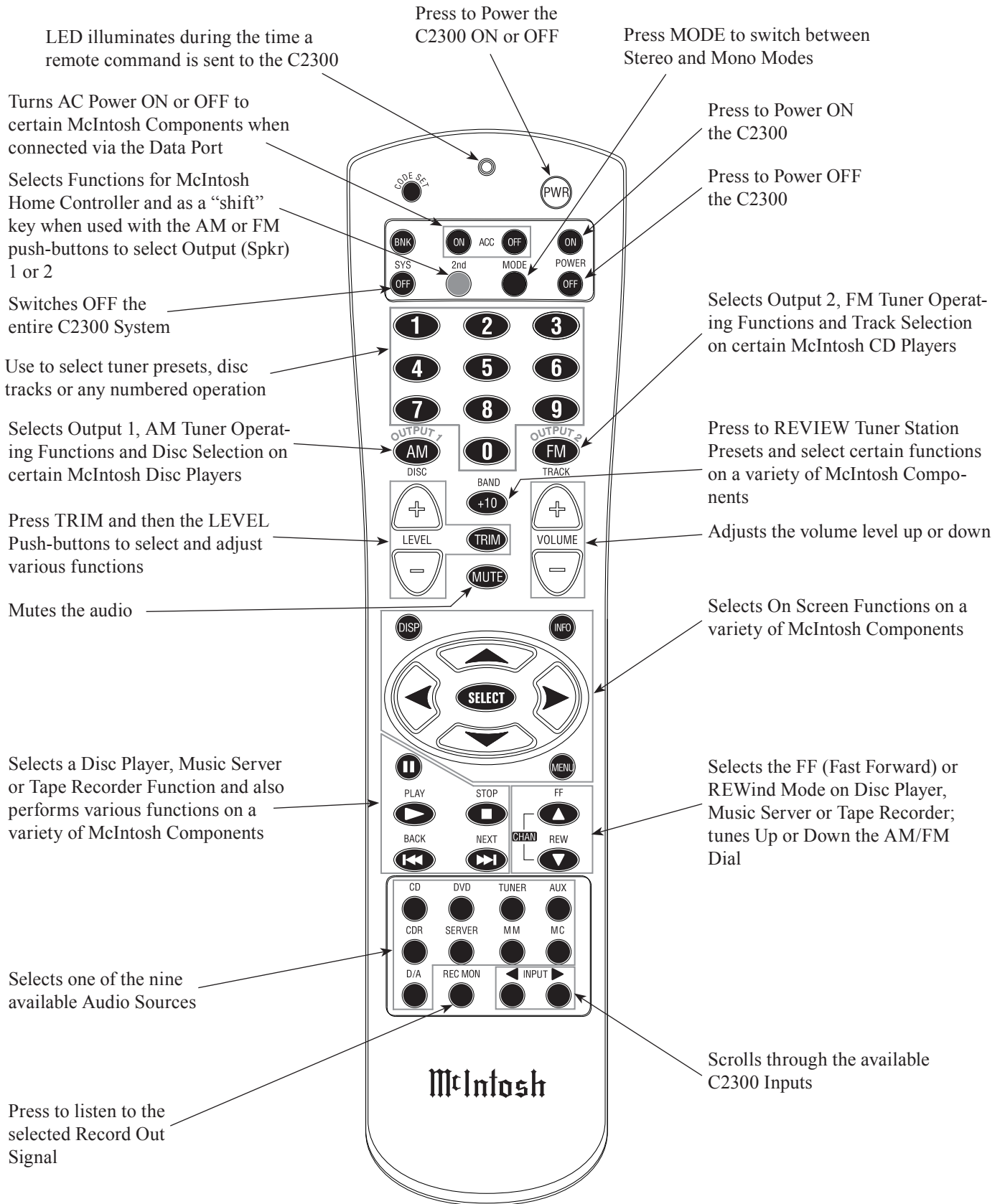

Note: Push-buttons whose function is not identified above are for use with other McIntosh Products.

How to use the Remote Control

The supplied Remote Control is capable of directly controlling the functions of contemporary McIntosh Source Components connected to the C2300 Tube Preamplifier.

Input Source Selection

Press the appropriate Source Push-button to select the desired program source. Sources may also be selected by pressing the ◀INPUT▶ push-button.

Mute

Press the MUTE Push-button to mute audio. The Record Signals present at the SRVR REC OUTPUT Jacks are not affected by the MUTE function. The C2300 Front Panel Alphanumeric Display will indicate the word MUTE.

Note: For additional information on the various Mute Modes refer to page 18.

Mode

Press the MODE Push-button to switch from Stereo to Mono for Monophonic listening.

Disc, Server and Tape Functions

Use these push-buttons to operate a DVD Player, CD Player, CD Changer, Music Server or Tape Recorder.

Numbered Push-buttons

Press Push-buttons 0 through 9 to access tuner station presets, tracks on discs or selections on a Music Server.

Disc and Track

Use the DISC and TRACK Push-buttons when a Disc Player or Music Server is being used.

Tuner Push-buttons

Press the AM or FM Push-button to select the desired broadcast band. Press and release the CHANnel Up▲ or Down▼ Push-button to move from station to station. Press and hold a CHANnel Up▲ or Down▼ Push-button to move continuously from station to station. Press the +10 Push-button to start the automatic brief audition of each of the presets stored in the tuner memory. Press +10 Push-button a second time to stop on a station preset.

Volume

Press the Up▲ or Down▼ VOLUME Push-button to raise or lower the listening volume level.

Note: The Record Signals present at SRVR OUTPUTS are not affected by volume changes.

Pause

Press Pause■ Pushbutton to perform various functions on a variety of McIntosh Components. It will also pause the playing of a disc or tape player. The Pause■ Push-button will also allow for quick exiting from the active menu when in the setup mode. The Pause■ Push-button is also used as an Enter Push-button with some McIntosh components.

Trim

Press the TRIM Push-button until the word “BALANCE ___” appears on the Alphanumeric display, then press the LEVEL Up▲ Push-button to emphasize the Left Channel or Down▼ Push-button to emphasize the Right Channel.

Press the TRIM Push-button until the word “TRIM _ _ _ _” appears on the Alphanumeric display, then press the LEVEL Up▲ or Down▼ Push-button to match the volume level of the previously selected Input.

Note: For additional information on the other Trim Functions refer to pages 16, 17 and 18.

Acc On

Press ACC ON to turn the power ON to a McIntosh Disc Player.

Acc Off

Press ACC OFF to turn the power OFF to a McIntosh Disc Player.

Amplifier Selection

Press the 2nd Push-button followed by the OUTPUT 1 or 2 Push-buttons either separately or together, to control the rear panel OUTPUTS 1, 2 which can feed signals to a Power Amplifier or other accessory component.



How to Operate the C2300

Power On

The Red LED above the STANDBY/ON Push-button lights to indicate the C2300 is connected to AC Power. To Switch ON the C2300, press the STANDBY/ON Push-button on the Front Panel or the PWR (Power) Push-button on the Remote Control. The title TUBE WARMUP will appear on the Front Panel Alphanumeric Display after Turn-On, with the Audio Outputs muted. Refer to figures 12, 13, 14 and 21.

Source Selection



Figure 12



Figure 13

Select the desired source using the INPUT Control or Remote Control.

Volume Control

Rotate the Front Panel VOLUME Control or use the VOLUME + (Up) or - (Down) Push-buttons on the Remote Control for the desired listening level.

Trim Functions

The C2300 has six different Trim Selections with Adjustments. The Trim Selections include Balance, Bass, Treble, Tone Bypass, Input Level Matching and Meter Illumination. The Trim Settings are stored in memory independently for each Input Source Selected, the only exception being

Meter Illumination setting of On or Off which is the same for all inputs.

BALANCE

Listening balance varies with different program sources, room acoustics and listening positions relative to the Loudspeakers. Use the Balance (Trim Function) as needed to achieve approximately equal listening volume levels in each Loudspeaker. To adjust the Balance perform the following:

1. Rotate the Front Panel TRIM SELECT Control or press the TRIM Push-button on the Remote Control until "BALANCE 00" appears on the Front Panel Alphanumeric Display.
2. Rotate the TRIM ADJUST Control or press the LEVEL + / - Push-buttons to emphasize the Left Channel or the Right Channel. Refer to figure 15.



Figure 15

The Front Panel Display indicates the Balance changes in steps from 0 to 107. After approximately 3 seconds the Alphanumeric Display returns to indicate the Source Selection and Volume Level. When the Balance is set to favor either left or right channel, the volume number indicated will have a "<" or ">" symbol on either side of the number. Refer to figure 16. To verify the Balance setting without



Figure 16

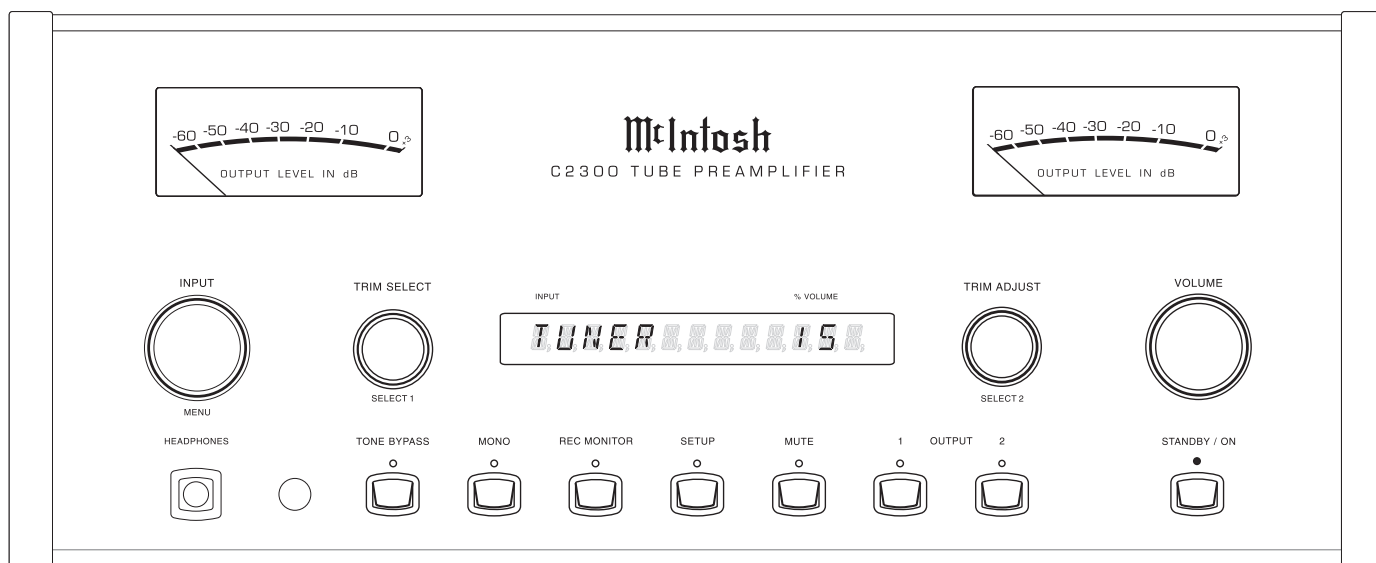

Figure 14

changing it, use the TRIM SELECT Control or TRIM Push-button and select Balance.

BASS

The Intensity of the Low Frequencies in the music can be increased or decreased by using the Trim Select and Trim Adjust Controls. To make adjustment perform the following:

1. Rotate the Front Panel TRIM SELECT Control or press the TRIM Push-button on the Remote Control until “BASS __” appears on the Front Panel Alphanumeric Display.
2. Rotate the TRIM ADJUST Control or press the LEVEL + / - Push-buttons to increase or decrease the volume level of the low frequencies. Refer to figure 17.



Figure 17

The Front Panel Display indicates the Bass changes in steps from -12dB to (+)12dB. After approximately 3 seconds the Alphanumeric Display returns to indicate the Source Selection and Volume Level.

TREBLE

The Intensity of the High Frequencies in the music can be increased or decreased by using the Trim Select and Trim Adjust Controls. To make adjustment perform the following:

1. Rotate the Front Panel TRIM SELECT Control or press the TRIM Push-button on the Remote Control until “TREBLE __” appears on the Front Panel Alphanumeric Display.
2. Rotate the TRIM ADJUST Control or press the LEVEL + / - Push-buttons to increase or decrease the volume level of the high frequencies. Refer to figure 18.



Figure 18

The Front Panel Display indicates the Bass changes in steps from -12dB to (+)12dB. After approximately 3 seconds the Alphanumeric Display returns to the indicate the Source Selection and Volume Level.

TONE ENABLE/BYPASS

With the Tone Bypass active, the Bass and Treble Settings for the currently selected Input Source are electronically bypassed. When the Tone Bypass is switched Off the previous settings for Bass and Treble will be restored. To

activate Tone Bypass perform the following:

1. Rotate the Front Panel TRIM SELECT Control or press the TRIM Push-button on the Remote Control until “TONE BYPASS” appears on the Front Panel Alphanumeric Display.
2. Rotate the TRIM ADJUST Control or press the LEVEL + / - Push-buttons to activate the Tone Bypass or deactivate the Tone Bypass. Refer to figure 19.



Figure 19

After approximately 3 seconds the Alphanumeric Display returns to indicate the Source Selection and Volume Level.

TRIM LEVEL

The Trim Level adjustments allows for making fine adjustments to the previously performed Trim Level Adjustments in the Setup Section of this Owner’s Manual on page 11. To make fine adjustment to the currently selected Input Source perform the following:

1. Rotate the TRIM SELECT Control or press the TRIM Push-button on the Remote Control until “LEVEL __” appears on the Front Panel Alphanumeric Display. Refer to figure 20.
2. Rotate the TRIM ADJUST Control or press the LEVEL + / - Push-buttons to adjust the volume level from -6dB to (+)6dB. Refer to figure 20.

After approximately 3 seconds the Alphanumeric Display returns to the indicate the Source Selection and Volume Level.



Figure 20

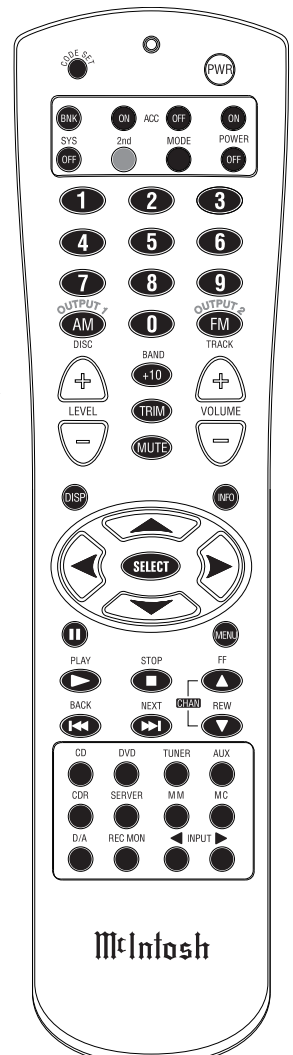

Figure 21



How to Operate the C2300, con't

METER ILLUMINATION

The C2300 Front Panel Meter Illumination may be switched On or Off by performing the following:

1. Rotate the TRIM SELECT Control or press the TRIM Push-button on the Remote Control until "METER ON" appears on the Front Panel Alphanumeric Display.
2. Rotate the TRIM ADJUST Control or press the LEVEL + / - Push-buttons to switch On or Off the Meter Illumination.

After approximately 3 seconds the Alphanumeric Display returns to the indicate the Source Selection and Volume Level.

Note: When the Main Power Control of the C2300 is connected to a McIntosh Power Amplifier with Remote Meter Illumination Control the C2300 Meter Illumination Setting of On or Off will also affect the Power Amplifier Meter Illumination.

PHONO ADJUSTMENTS

When the Phono MC or Phono MM Input is selected an additional TRIM SELECT FUNCTION becomes available for adjustment. Perform the following steps to make the Phono Trim Adjustments:

1. Select either the Phono MM or Phono MC Input using the INPUT Control.
2. Rotate the TRIM SELECT Control or press the TRIM Push-button on the Remote Control until "PHMM _ _ _ PF" or "PHMC _ _ _ OHM" appears on the Front Panel Alphanumeric Display. Refer to figures 22 and



Figure 22



Figure 23

- 23.
3. Rotate the TRIM ADJUST Control or press the LEVEL + / - Push-buttons to select from the available values of cartridge loading (Ohms for a Moving Coil Cartridge or Capacitance for a Moving Magnet Cartridge) that comes closest to the Cartridge Makers recommend value.

After approximately 3 seconds the Alphanumeric Display returns to the indicate the Source Selection and Volume Level.

Tone Bypass

Press the TONE BYPASS Push-button to Bypass the Tone Control Circuitry, providing a flat frequency response. If

the AUTOTONE circuit is set to the On position in Setup Mode, the C2300 will remember for each input whether the Tone Bypass is active. The Front Panel LED will illuminate indicating the BYPASS Mode is active.

Mono

Press the Front Panel MONO Push-button or the MODE Push-button on the Remote Control to combine left and right stereo signals to a Monophonic Signal. The Front Panel LED will illuminate indicating the MONO Mode is active. The C2300 automatically stores into memory for each Input, the Selection of the Stereo or Mono Mode.

Note: The signals at the SRVR OUT (REC) Jacks are not affected.

Record Monitor

Press the REC MONITOR Push-button to hear the SERVER Playback Signal during the recording process.

Setup

Pressing the SETUP Push-button activates the Setup Mode of the C2300 and allows customizing various operating functions. Refer to page 11 for additional information.

Mute

Press the MUTE Push-button, on the C2300 Front Panel or on the Remote Control, to Mute the Audio at the OUTPUTS Connectors and HEADPHONES Output Jack. The Front Panel Alphanumeric Display will indicate the Input Source Name followed by the word MUTE in place of the actual volume setting. Refer to figure 24.



Figure 24

Pressing the Mute Push-button a second time or adjusting the volume control (either the Front Panel or Remote Control) will un-mute the C2300.

If the Front Panel MUTE Push-button is pressed for at least 3 seconds, the C2300 will mute the OUTPUTS connectors, yet listening with headphones will continue until the Mute Push-button is pressed again for 3 seconds. The Front Panel Alphanumeric Display will indicate the Input Source Name, Volume Setting and a Dot. Refer to figures 25 and 26.



Figure 25



Figure 26

Output 1 and 2

Press the Front Panel OUTPUT 1 / OUTPUT 2 Push-button or by using the Remote Control and pressing the 2nd Push-button followed by the OUTPUT 1 / OUTPUT 2 Push-button to send audio to separate Power Amplifiers connected to the rear panel OUTPUTS 1 or 2 Jacks. It also activates the POWER CONTROL OUTPUT 1 /OUTPUT 2 Jacks on the rear panel of the C2300. To stop the Audio and Power Control Signals from going to the separate Power Amplifiers press the same Push-button(s) a second time.

Headphones Jack

Connect a pair of dynamic headphones with a 1/4" (0.635cm) stereo phone type plug to the Headphones Jack for private listening.

Output Meters

The C2300's Output Meters indicate the Output Voltage available at the MAIN and OUTPUT 1 & 2 Jacks to drive Power Amplifiers. Refer to figure 27. The Meters are calibrated in dB (decibels) and respond to all the peaks contained in the musical information. They indicate to an accuracy of at least 95% of a single cycle from a 2000Hz tone burst.

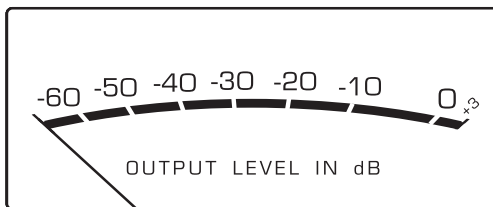

Figure 27

The Meter Electronic Circuitry "Time Stretches" the Meter Drive Signal so the Meter Pointer pauses just long enough for the human eye to see it and is followed by a moderate decay rate.

How To Make A Recording

1. Select the Source Input Signal you wish to record.
2. Adjust the record level using the recorder volume control and proceed with the recording process.
3. To listen to the playback of the program source just recorded, press the RECord MONITOR Push-button.

Note: The C2300 SRVR (REC) OUTPUTS are not affected by the VOLUME or BALANCE controls.

Reset of Microprocessors

In the unlikely event the controls of the C2300 stop functioning, the microprocessors can be reset by performing the following:

1. Press and hold in the STANDBY/ON Push-button for approximately five seconds and then release the push-button.
2. Press the STANDBY/ON Push-button, the C2300 will resume normal operation.

Note: This can be performed with the C2300 On or in the Standby Mode.

Technical Description

The McIntosh engineering staff has created a Tube Pre-amplifier without compromise, using the most advanced McIntosh circuit design concepts. Many months of design, testing and measuring were required. Extensive controlled listening tests, the ultimate form of measuring, were made before the final design was accepted.

Silent Audio Switching

All signal switching in the C2300 is done by Electro-Magnetic devices. Electro-Magnetic Switching is a proven technology that uses the latest in materials and manufacturing methods. Each switch consists of a glass tube that is filled with an inert oxygen-free atmosphere and sealed with tiny leads protruding from either end. These leads extend into the tube and overlap one another with a separation of a few thousandths of an inch. The leads are made from a ferrous material that is influenced by a magnetic field. They are first plated with gold as a base material, then with rhodium and finally ruthenium. Ruthenium is the best contact material known. Refer to figure 28.

The glass assembly is then placed in the center of a multilayer coil of copper wire. The entire assembly is molded together in a tough shock absorbing material. The switch and coil connectors extend from the bottom in the form of printed circuit board terminals.

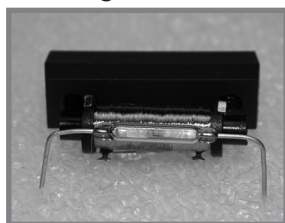

Figure 28

When a DC voltage is applied to the coil, current flows and creates a magnetic field. The force of the field causes the leads to bend and contact one another inside the sealed glass tube. The inert gas eliminates corrosion of the contacts and insures a low resistance, distortion free switch.

All inputs, outputs, and data ports are controlled by logic circuits in the C2300. The logic is changed by Front Panel Push-buttons or by a microprocessor IR decoder. This microprocessor IR decoder is programmed with exclusive McIntosh software. It receives data from the Front Panel or Sensors and provides the command signals for input switching, data switching, tone control and volume control.

Phono Circuitry

McIntosh has long been known for its expertise in low noise discrete amplifier circuits. The MC Amplifier consists of two stages, which together have a gain of 60dB at 1000Hz. The first stage (pre-preamplifier) is a new design Moving Coil Preamplifier using special ultra low noise circuitry with out the need for a step-up transformer. It offers

the ability to change the input impedance from 25 ohms to 1000 ohms in six steps to match a wide variety of Moving Coil Cartridges. The C2300 utilizes a double filtered power supply design, just for the Moving Coil Preamplifier.

The second (compensation) amplifier stage uses 12AX7A tubes. Its input stage has been optimized for low noise and low distortion performance. With high open loop gain, negative feedback is used around the Phono Amplifier to further reduce noise, distortion and has a very wide dynamic range. The feedback network also provides precision RIAA frequency compensation. The output is buffered by a unity gain amplifier for low output impedance.

The MM Phono Amplifier uses 12AX7A tubes. Its input stage has been optimized for low noise and low distortion performance. It offers the ability to change the load capacitance from 50 pF to 750 pF in 50pF steps to match a wide variety of Moving Magnet Cartridges. With high open loop gain, negative feedback is used around the Phono Amplifier to further reduce noise, distortion and has a very wide dynamic range. The feedback network also provides precision RIAA frequency compensation. The output is buffered by a unity gain amplifier for low output impedance.

Tone Control Circuitry

A control attenuator inserts a series tuned circuit into either the feedback or input section of the tone amplifier. The level is set by a digitally controlled electronic attenuator. This provides a 12dB boost or cut in 1dB steps at the frequency of the tuned circuit. The Bass turn-over frequency is 200Hz. The Treble turn-over frequency is 2kHz. The overall gain of the stage is 0dB when the tone is adjusted to flat. The TONE BYPASS switch removes all tone control circuits from the signal path.

Volume Adjustments

The most frequently operated control on a Preamplifier is the Volume Control. So it is no surprise that McIntosh has devoted a substantial amount of time in pursuit of the "Perfect Volume Control System". Conventional Mechanical Controls have poor tracking especially when it comes to maintaining channel balance and after a period of time they tend to introduce noise into the audio signal, as they are rotated. The one desirable thing they have is the rate of change in volume for degrees of rotation, known as the audio taper. Using Electronic Circuitry for controlling the volume can be designed to be free from noise and maintain channel balance, however the audio taper produced by the typical Electronic Volume

Control Circuit is unacceptable for use in the C2300, as it does not match the classic McIntosh Volume Control Audio Taper. The C2300 incorporates electronic circuitry together with sophisticated firmware to produce electronically the classic McIntosh Volume Control Audio Taper, while maintaining the channel balance and freedom from control noise.

The Volume Control on the Front Panel of the C2300 is actually a special digital optical encoder. As the Volume Control is rotated, a beam of Infra Red Light is picked up by two internal sensors as a series of digital pulses. Refer to the exploded view in figure 29. The number of and time between pulses are counted by a Microprocessor which in turn controls the McIntosh designed Precision Electronic Attenuator that provides 213 steps in 0.5dB increments and maintains the channel balance to within + 0.1dB.

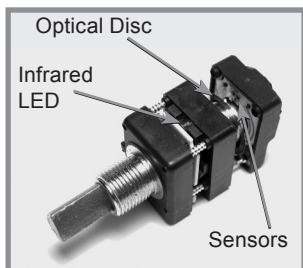

Figure 29

With most Preamplifiers the Volume Control is placed ahead of the Amplifying Circuitry providing large dynamic range and freedom from input overload however, background noise level is higher at lower settings of the volume control. By placing the Volume Control after the Amplify-

ing Circuitry there is lower background noise however, a reduction in dynamic range and input overload is the result. The only correct way to design a high performance Preamplifier is with two volume controls. This provides the benefits of wide dynamic range, freedom from Input overload and a background noise level that actually goes down as the volume control setting is reduced. The special controlling circuitry for this dual volume control design is known as the McIntosh “Dynamic Control Multiplexer”.

Meter and Circuitry

McIntosh solved the problems with ordinary meters in the C2300. By developing electronic circuits the meters are made to respond to short intervals with an accuracy of 95%! To permit the eye to see such high speed motion, the electronic circuits that drive the meter pointer are time stretched. Special logarithmic circuitry allows the meter to indicate a 60dB plus range, without resorting to a Meter Range Switch.

Power Supply Circuits

To compliment the design of the C2300 there are fully regulated power supplies. The special “R” core transformers supplies the necessary voltage/current for the low and high voltage regulated circuitry.

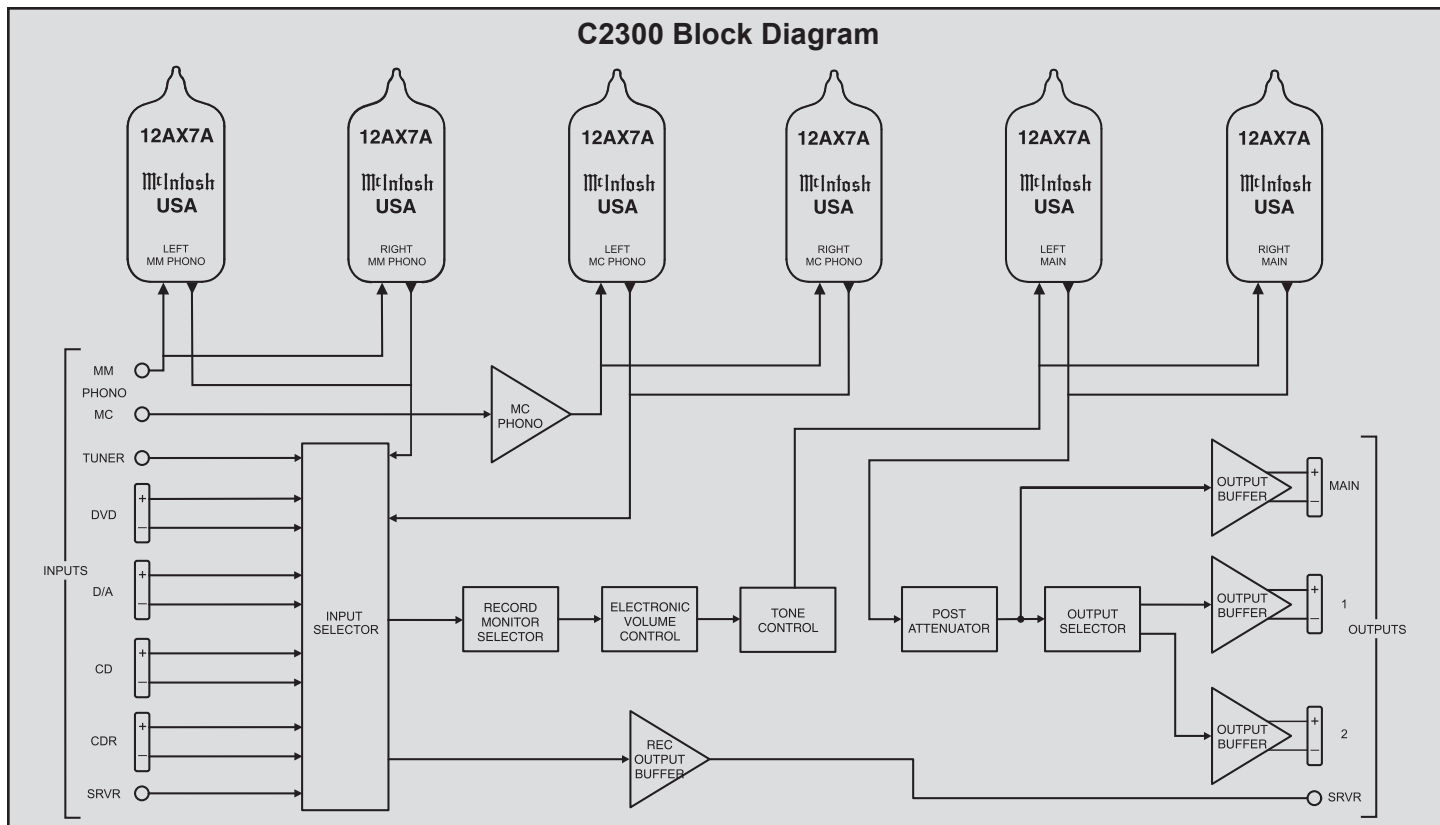



Specifications

Frequency Response

+0, -0.5dB from 20Hz to 20,000Hz

+0, -1dB from 10Hz to 100,000Hz

Total Harmonic Distortion

0.08% from 20Hz to 20,000Hz

Rated Output (Main)

2.5V Unbalanced, 5V Balanced

Maximum Voltage Output

8V RMS Unbalanced, 16V RMS Balanced

Sensitivity (for rated output)

High Level, 450mV unbalanced, 900mV balanced

Phono MM, 4.5mV

Phono MC, 0.45mV

Signal To Noise Ratio (A-Weighted)

High Level, 93dB

Phono, 80dB

Input Impedance

High Level, 20K ohms unbalanced, 40k ohms balanced

Phono MM, 47K ohms; 50 to 750pF, in 50pF steps

Phono MC, 25, 50, 100, 200, 500 or 1,000 ohms; 100pF

Maximum Input Signal

High Level, 5V Unbalanced, 10V Balanced

Phono MM, 50mV

Phono MC, 5mV

Voltage Gain

High Level to SRVR(REC) Output: 0dB

High Level to Main Output: 15dB

Phono MM to Record Output: 40dB

Phono MC to Record Output: 60dB

Output Impedance

220 ohms

Headphone Load Impedance

16 ohms to 250 ohms

Tube Compliment

MM Phono Circuitry: 2 - 12AX7A

MC Phono Circuitry: 2 - 12AX7A

High Level Circuitry: 2 - 12AX7A

Power Requirements

100 Volts, 50/60Hz at 75 watts

110 Volts, 50/60Hz at 75 watts

120 Volts, 50/60Hz at 75 watts

220 Volts, 50/60Hz at 75 watts

230 Volts, 50/60Hz at 75 watts

240 Volts, 50/60Hz at 75 watts

Standby Power, less than 2 watts

Note: Refer to the rear panel of the C2300 for the correct voltage.

Overall Dimensions

Width is 17-1/2 inches (44.45cm)

Height is 6 inches (15.24cm) including feet

Depth is 18 inches (45.72cm) including the Front Panel,

Knobs and Cables

Weight

29.5 pounds (13.41 kg) net, 44.9 pounds (20.41 kg) in shipping carton

Shipping Carton Dimensions

Width is 25 inches (63.5cm)

Depth is 27 inches (68.6cm)

Height is 12 inches (30.5cm)

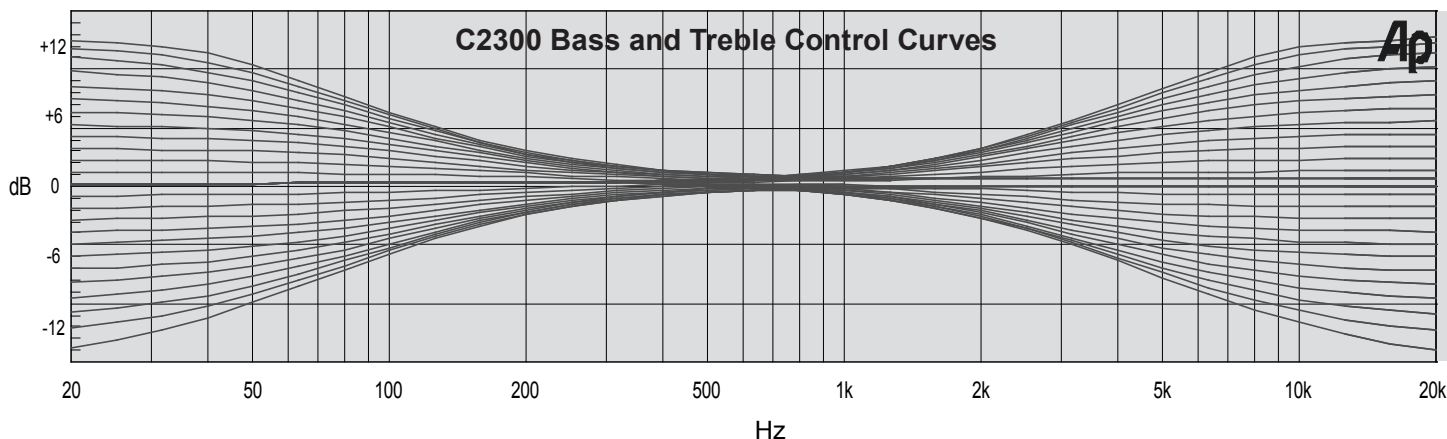

Packing Instructions

In the event it is necessary to repack the equipment for shipment, the equipment must be packed exactly as shown below. It is very important that the four plastic feet are attached to the bottom of the equipment. This will ensure the proper equipment location on the bottom pad. Failure to do this will result in shipping damage.

Use the original shipping carton and interior parts only if they are all in good serviceable condition. If a shipping carton or any of the interior part(s) are needed, please call or write Customer Service Department of McIntosh Laboratory. Refer to page 4. Please see the Part List for the correct part numbers.

Quantity	Part Number	Description
1	033888	Shipping carton only
4	033887	End cap
1	033697	Inside carton only
1	034414	Top pad (foam)
1	034301	Bottom pad
4	017937	Plastic foot
4	100159	#10-32 x 3/4" screw
4	404080	#10-7/16" Flat washer

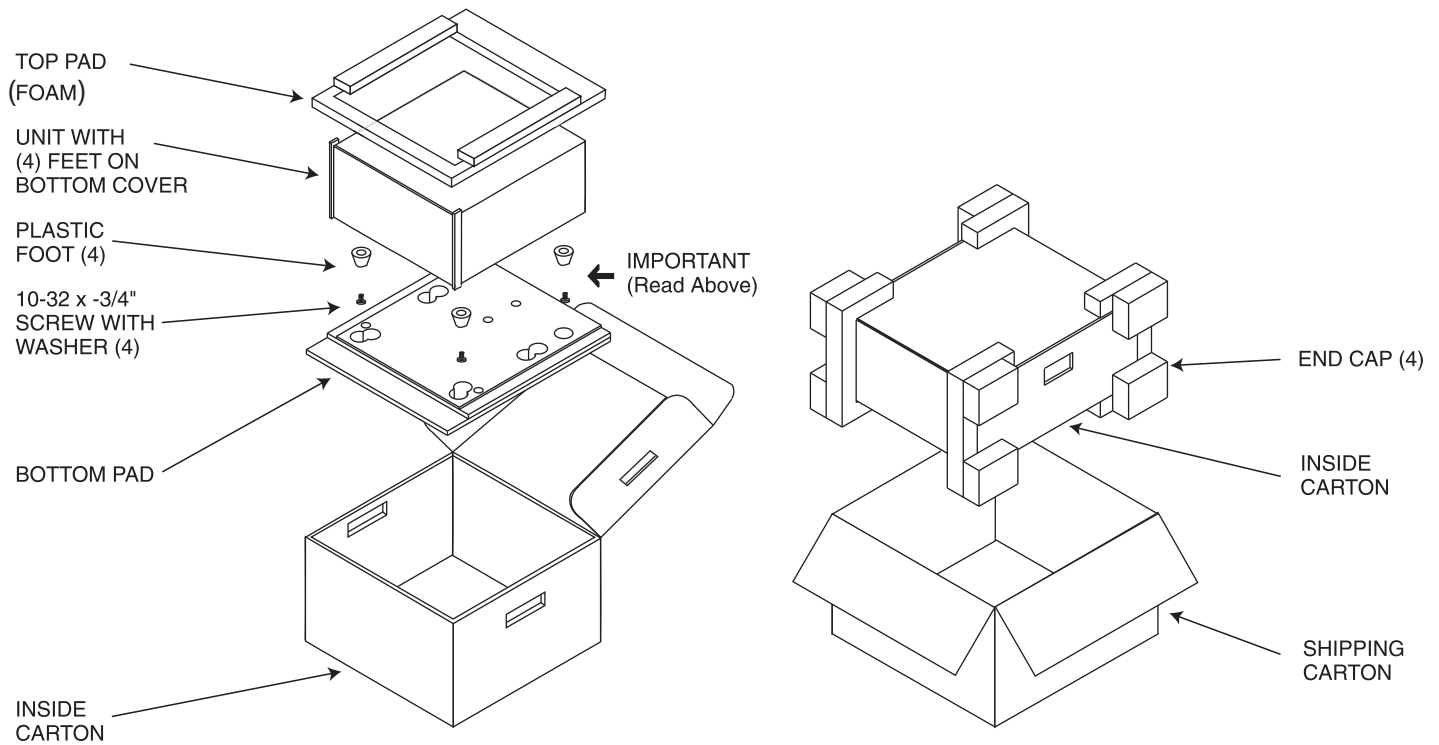



McIntosh Laboratory, Inc.
2 Chambers Street
Binghamton, NY 13903

The continuous improvement of its products is the policy of McIntosh Laboratory Incorporated who reserve the right to improve design without notice. Printed in the U.S.A.

McIntosh Part No. 04102700